

Yolo County Transportation District  
350 Industrial Way, Woodland, CA 95776  
(530) 661-0816 - (530) 661-1732 fax  
www.yolobus.com

City of Davis - City of West Sacramento - City of Winters  
City of Woodland - County of Yolo  
Ex Officio: CalTrans District 3 - University of California, Davis

## ADDENDUM 2

Covering

### IFB 2009-18 BUS STOP SITE FURNISHINGS

ADDENDUM NO. 2  
DATE ISSUED: October 30, 2009  
ISSUED BY: Kellie Herger, Buyer  
RFP/IFB/RFQ NO. 2009-18

1. Option: Bid on additional mounting hardware for schedule display QTY 100 (50 sets – 2 per sign), see sample hardware below. See attached amended bid form

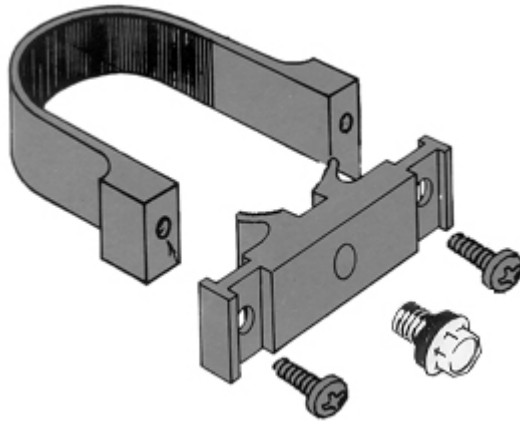

2. Please provide a minimum of three (3) references where your product has been installed using in-shelter solar lighting and perforated metal products. References are to include contact name, email address, phone number and mailing address.

3. Questions and Answers:

**Question:** Page 5 of 24, Section II- Schedule Display indicates a size of 9.5" x 24" yet is listed as a 10" x 24" on the bid form found on page 22. Please confirm which size this is to be.

**Answer:** The correct size is 9.5" x 24"

**Question:** It is to be mounted to a 2 3/8" pole but there is not desired pole height indicated. What provisions should be provided for anchoring the pole to the concrete?

**Answer:** YCTD's IFB is for materials only; installation will be performed under a separate contract.

**Question:** Is there an illustration available to assist bidders in matching the desired aesthetic?

**Answer:** Yes, see sample pictures attached to this addendum.

**Question:** Page 22 of 24, Section V- Bid Forms calls out for a 22" x 33" map display case as "(must be compatible with existing Tolar perforated metal bus shelters) including hardware." Please provide detail (drawing) required to insure specified compatibility with existing Tolar shelters.

**Answer:** Attached are pictures and specifications of the map display case.

**Question:** Do you have any sketches in addition to the written specifications? If so could you please send over to me, I just seem to be a better visual person.

**Answer:** See sample pictures attached to this addendum.

**Question:** Are you specing a certain model number for the receptacles, benches, and shelters from a certain company? Thank you

**Answer:** No.

**Question:** YCTD is requesting a sixty day turn around on orders (Page 3 of 24). Is ninety days acceptable?

**Answer:** Sixty days is preferred, but will accept 90 days.

**Question:** What is the minimum quantity described on the bid form (Page 22 of 24), the minimum quantity that will be released in any YCTD delivery order? It should be noted that releases of smaller quantities than those specified on the bid form may result in increased costs.

**Answer:** YCTD will issue one Delivery Order for the minimum number of units within the contract period. YCTD may also order more than the minimum quantity through the contract period on separate Delivery Orders

**Question:** Is the perforated metal bus shelter (page 5 of 24) required to have any type of full guttering system or is YCTD accepting a simple rain diverter from the front of the shelter?

**Answer:** YCTD will accept a rain diverter from the front of the shelter. A full guttering system is acceptable, though not required.

**Question:** For the smaller shelter, will you accept a roof length of slightly under 9' rather than 10'?

**Answer:** YCTD shall accept a roof length under 10' (but no less than 8.5') **IF** the accompanying 4' bench **AND** a minimum of 36" wide wheelchair space is available and is covered under the roof.

**Question:** What type of roof panels are required? Bronze Lexan Thermoclear or powder coated aluminum?

**Answer:** YCTD will accept either type of roof panel.

**Question:** Are the panels required to be secured with gasketed, extruded pressure ribs or simple flat bar?

**Answer:** YCTD shall accept panels: riveted to the frame, OR secured with gasketed, extruded pressure ribs, OR secured with a simple flat bar, OR any other durable method of panel installation.

**Question:** What is the gauge required for the perforated metal panels? What is the hole spacing to be?

**Answer:** Shelter panels shall be a minimum of 16 gauge. Holes shall be 1/4" diameter on 3/8" centers. Bench and Waste Receptacle panels shall be a minimum of 11 gauge.

**Question:** Are the mounting shoes required to have adjustment? What is that length?

**Answer:** Yes. The length needs to be adjustable up to 12".

**Question:** Are the anchors to be zinc or stainless steel?

**Answer:** Stainless steel.

**Question:** Regarding the solar lighting, are the solar collector panels to be the only element of the solar on the roof and is it to be mounted flat on the roof?

**Answer:** Yes.

**Question:** Regarding the solar lighting, are the batteries, lighting and controller are they required to be under the roof line for ease of maintenance?

**Answer:** Solar lighting components shall be in an aluminum enclosure. The aluminum enclosure shall be mounted to the inside top of the shelter using vandal resistant hardware.

**Question:** Is five days of battery back-up acceptable for the solar lighting?

**Answer:** Yes.

**Question:** Is 7 foot candle, evenly dispersed at seat level and acceptable light level?

**Answer:** Yes.

**Question:** Is a minimum of 2 foot candle evenly dispersed at ground level and acceptable light level?

**Answer:** Yes.

**Question:** Page 5 Section II Specifications. The shelter description is very vague and can be interpreted different ways. This will result in comparing "apples and oranges" when the bids are submitted. Can you furnish a drawing or drawings illustrating the shelter designs you are looking for?

There is no description of the window/wall material, please clarify. Please provide a drawing of illustration, details or more information to explain how the Map Display Panel is to be attached to the shelter.

**Answer:** Please see attached map display case specifications and sample pictures.

**Question:** Page 5 Section II Specifications. Regarding the Perforated Metal Bench:

Is the bench to be free standing and/or wall attached?

**Answer:** Free standing.

**Question:** Do you have a drawing or details illustrating the bench design you have in mind?

**Answer:** Please see attached sample pictures

**Question:** Can the bench be extruded aluminum in the length you specify with the finish specified and with anti-vagrant bars? The extruded aluminum bench will not be of perforated metal but will be sturdier and can have draining holes added if you feel this is needed.

**Answer:** No. The bench must be constructed using perforated metal.

**Question:** Also, do you have a drawing or illustration of the 32 gallon waste receptacles and 10 x 26" tall schedule display panel w/anti-theft mounting? It is not clear what you have in mind for these items.

**Answer:** Please see attached sample pictures. The schedule display holder specifications are attached to this addendum. A picture of the mounting hardware is shown on Item 1 above.